



*RAINBOW WARRIOR RACING  
UNIVERSITY OF HAWAI'I AT MANOA*



# **SPONSOR HANDBOOK 2023 - 2024**

# ABOUT US

The Rainbow Warrior Racing (RWR) Team is a team of Mechanical Engineering students from the University of Hawaii at Manoa (UHM) whose goal is to produce a high performance winning electric racing vehicle to compete in one of the most prestigious collegiate design competitions in the world. Throughout the course of the year members of the team will be designing, analyzing, manufacturing, and testing a fully functional electric race car, from the tires to the batteries. The purpose of the project is to represent the State of Hawaii at the Formula Society of Automotive Engineers (FSAE) Electrical Vehicle 2024 Competition.

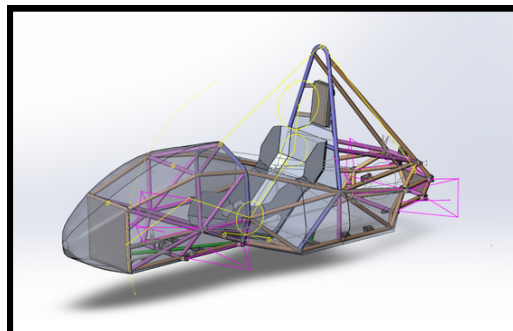
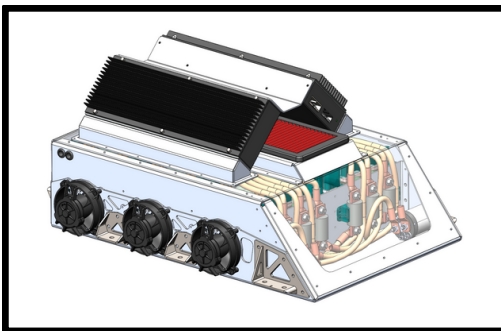
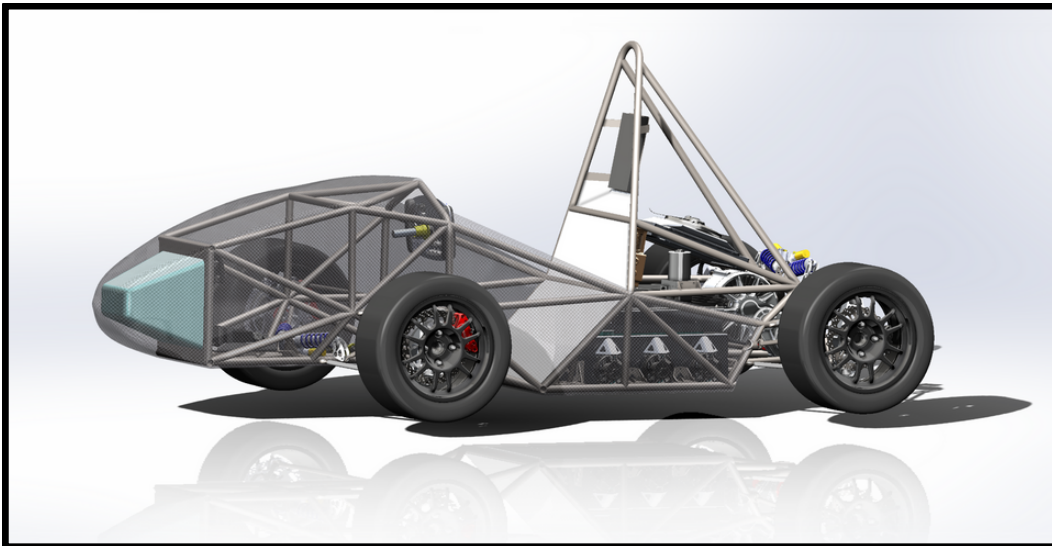

# COMPETITION

Since 1981, the Society of Automotive Engineers (SAE) has held an annual design competition called the Formula SAE (FSAE). This competition is an international contest in which collegiate student-led teams are to design, analyze, manufacture, and test and validate formula-style open wheel race cars from scratch. With this goal students are pushed to apply their technical knowledge gained from their experience in school to a real-world application.

The 2024 competition will be held on June 12th through the 15th in Brooklyn, Michigan at the Michigan International Speedway. There are a total of 75 teams actively registered to compete in the 4-day event. Top universities around the world will arrive to test their vehicles in areas such as performance, design, management, and choices teams made throughout the year by a series of different events. At the end of the competition the teams who performed the best will be recognized and awarded.



# TEAM OVERVIEW

The 2023-2024 racing season is the 12th Anniversary of the UH RWR team itself. From its inception until 2019 the UH RWR team was part of the internal combustion (IC) competition, but in 2020 the team made the switch to the FSAE Electric powered vehicle. This change came about to be more in line with the State of Hawaii's efforts to be leaders in renewable energy and sustainability. This year will be the 4th year that the UH RWR team has been working on the electric vehicle (EV) and the team has been working hard to produce the University's first EV to compete in the FSAE Competition in June 2024.

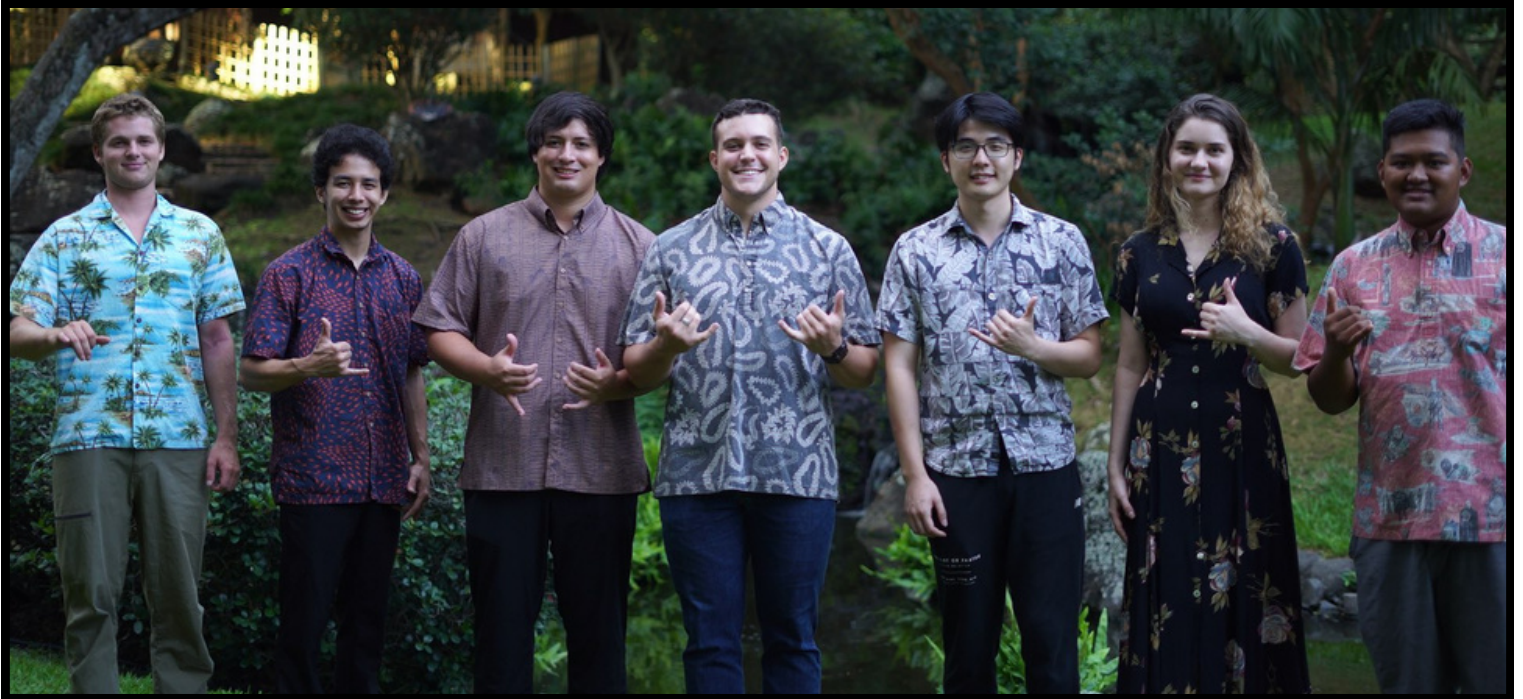

# 2023 - 2024 BUDGET

## VEHICLE PARTS EXPENSES

POWERTRAIN	\$3,000
SUSPENSION	\$1,500
CHASSIS	\$2,000
<b>TOTAL</b>	<b>\$6,500</b>

## OPERATING EXPENSES

FSAE REGISTRATION	\$2,750
SHIPPING	\$5,000
COMPETITION SUPPLIES	\$4,700
<b>TOTAL</b>	<b>\$12,450</b>

## COMPETITION EXPENSES

AIRFARE	\$10,000
LODGING	\$3,000
GROUND TRANSPORT	\$1,900
<b>TOTAL</b>	<b>\$14,900</b>

**GRAND TOTAL: \$33,850**

While the University of Hawaii at Manoa provides us with workshop space and basic project guidance, we rely solely on outside donations and fundraising to support our project.

We gladly welcome both cash and in-kind donations such as goods, services, and materials. Fair market value of in-kind donations will be utilized to determine the level of support. We are able to provide a 501(c)3 tax receipt, making all donations tax deductible. We also welcome any special requests donors may have in relation to their support.

# SPONSORSHIP BENEFITS

## PLATINUM \$20,000+

- In addition to the benefits of the GOLD level:
- 8"x12" company logo on HOOD of vehicle
- Dedicated logo banner hung in RWR workshop at UH Manoa
- Availability of team to assist in company events upon request.
- Ability to showcase vehicle at company workplace upon request

## GOLD \$10,000+

- In addition to the benefits of the SILVER level:
- 6"x10" company logo on SIDE of vehicle
- Access to RWR team member resume book
- Honorable mention on any RWR media / news appearances.

## SILVER \$5,000+

- In addition to the benefits of the BRONZE level:
- 5"x8" company logo on SIDE of vehicle
- Company logo and description posted on all RWR social media platforms

## BRONZE \$1,000+

- In addition to the benefits of the ASSOCIATE level:
- 3"x5" company logo on SIDE of vehicle
- Company logo on team banner

## ASSOCIATE \$100+

- Company name, link, and logo on RWR website
- Invitation to vehicle unveiling and RWR events.

Upon completion of the vehicle, Rainbow Warrior Racing team looks to maximize media exposure and public appearances. In addition to showcasing the vehicle outfitted with sponsor logos on news, journal, television, and social media outlets, Rainbow Warrior Racing team will display the vehicle at a wide range of events from automotive shows to engineering expos. Such exposures will continue even after competition as future teams will utilize said vehicle for promotional events. All donors will gain visibility , recruiting, and engagement benefits while helping advance the education and professional development of Rainbow Warrior Racing members for years to come.

## MAHALO TO OUR CURRENT SPONSORS

SERVCO, HECO, ULUPONO, HEI, SOLIDWORKS



# JOIN OUR TEAM

Aloha,

This year is exceptionally exciting for our team, as it represents the culmination of years of hard work and dedication. We are proud to carry on the legacy that has been built over the past years. Our EV-Formula race car holds immense significance for both the team and the University, as we aspire to be the first team from the State of Hawaii to create a fully functional and competition-ready EV Formula car. Your support will be instrumental in helping us achieve this goal.

Being from Hawaii, we recognize the importance of representing our state in such a prestigious competition. While other states have multiple teams, each representing their schools, the RWR team will represent the entire State of Hawaii.

We extend our heartfelt gratitude for your time and consideration. If you have any questions or would like more information about our team or sponsorship opportunities, please don't hesitate to contact us. Your support in any form will directly contribute to our success as a team.

Mahalo Nui Loa,

Andrew Fiala

*ANDREW FIALA*

Project Manager

Website: <https://me.hawaii.edu/design/rwr/>

Email: [rainbowwarriorracingev@gmail.com](mailto:rainbowwarriorracingev@gmail.com)

Instagram: [@rainbowwarriorracing](https://www.instagram.com/rainbowwarriorracing)

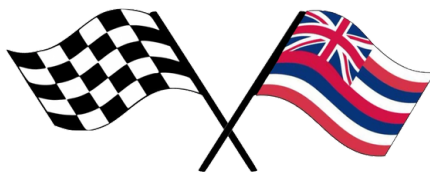



# DONATION FORM

Please provide the requested information and send your tax-deductible donation along with this form to the following address:

University of Hawaii at Manoa c/o Formula SAE

ATTN: Andrew Fiala

2540 Dole St. Holmes Hall 302

Honolulu, HI 96822

Please make checks payable to: "University of Hawaii Foundation"

Memo: "RWR UH Formula SAE"

NAME / ORGANIZATION: \_\_\_\_\_

MAILING ADDRESS:

CITY: \_\_\_\_\_ STATE: \_\_\_\_\_ ZIP CODE: \_\_\_\_\_

ORGANIZATION WEBSITE: \_\_\_\_\_

DONATION VALUE (FAIR MARKET VALUE FOR GIFTS IN KIND):

\_\_\_\_\_

CONTACT NAME: \_\_\_\_\_

PHONE NUMBER: \_\_\_\_\_

FAX: \_\_\_\_\_

EMAIL: \_\_\_\_\_

DONOR SIGNATURE: \_\_\_\_\_ DATE: \_\_\_\_\_

QUESTIONS? INQUIRIES?

ANDREW FIALA - PROJECT MANAGER

AFIALA@HAWAII.EDU

DESMOND BUSTAMANTE - MARKETING MANAGER

DESMOND9@HAWAII.EDU



UNIVERSITY  
of HAWAII®  
MĀNOA